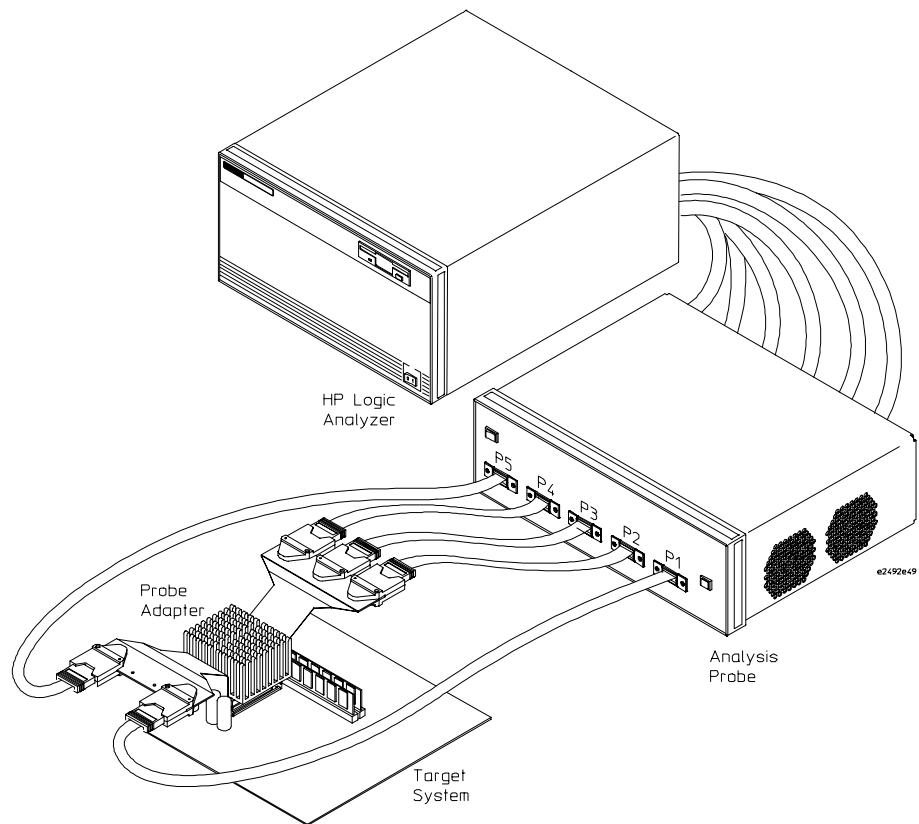

Installation Guide

Publication number E2492-92005
May 1999

© Copyright Hewlett-Packard Company 1999
All Rights Reserved

HP E2492D Probe Adapter for the Intel®Celeron™ Processor

Installation at a Glance



This Installation Guide explains how to install Hewlett-Packard's probe adapter for the Intel®Celeron™ processor in the 370-pin PPGA package. The probe adapter provides a quick and reliable connection from a processor to the HP E2487A/C Analysis Probe. The analysis probe then connects to your HP logic analyzer for state analysis.

Installation Overview

- Remove the processor.
- Install the probe adapter.
- Connect the processor the probe adapter.
- Connect the probe adapter to the HP E2487A/C analysis probe.

Installation

- 1 Remove the clip and heatsink from the processor on the target system.
- 2 Remove the processor from the socket on the target system.
- 3 Install the probe adapter on the target system. Ensure that the connector is fully seated.
- 4 Install the processor on the socket of the probe adapter. Ensure that the connector is fully seated.

CAUTION

Bending the flexible cable beyond the minimum bend radius will shorten the life of the probe adapter. See the dimension diagram the end of this document for minimum bend radius.

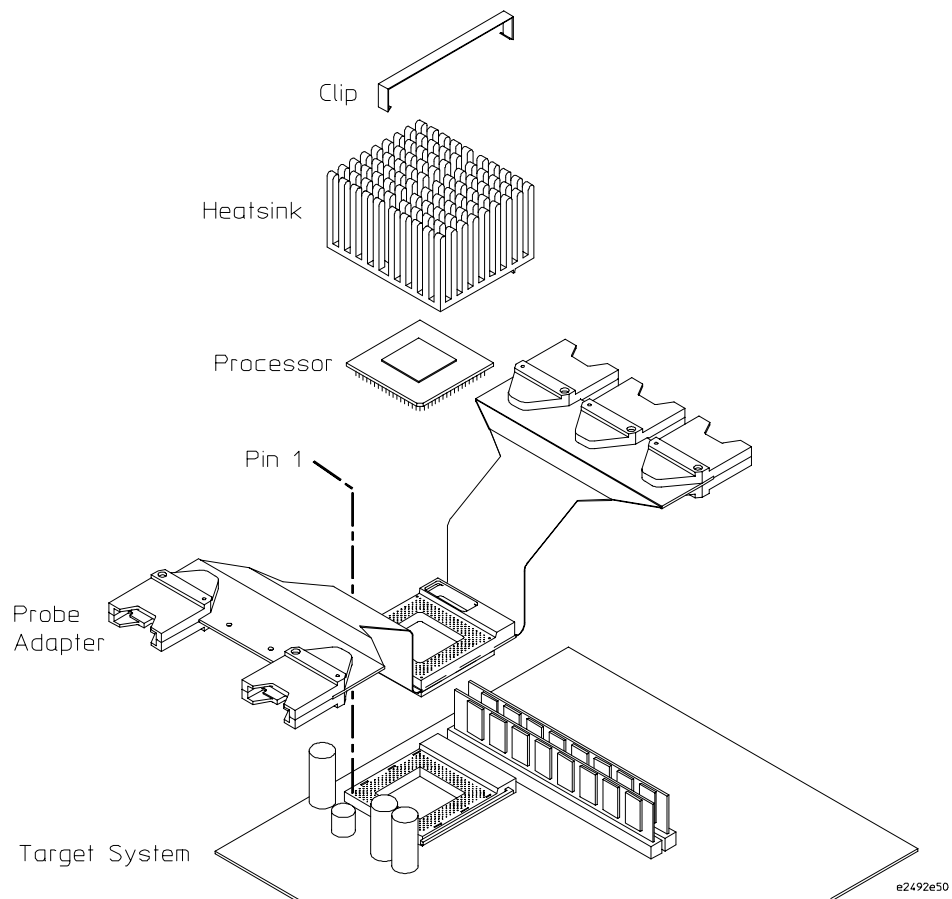

Installation

- 5 Use the clip to attach the heatsink to the socket on the probe adapter.

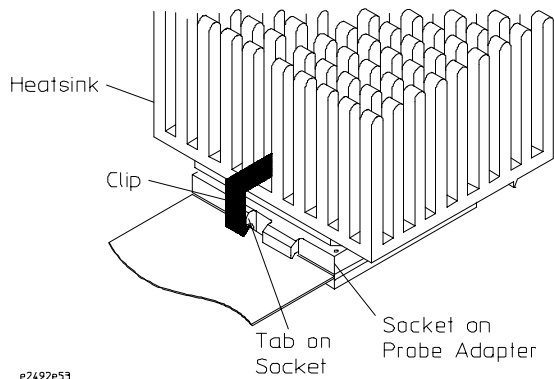

- 6 Connect the probe adapter to the HP E2487A/C Analysis Probe

The probe adapter has five high-density connectors, labeled Cable 1 through Cable 5. The HP E2487A/C Analysis Probe also has five high-density cabled connectors, labeled P1 through P5. Connect the probe adapter cables to the correspondingly-numbered analysis probe cables.

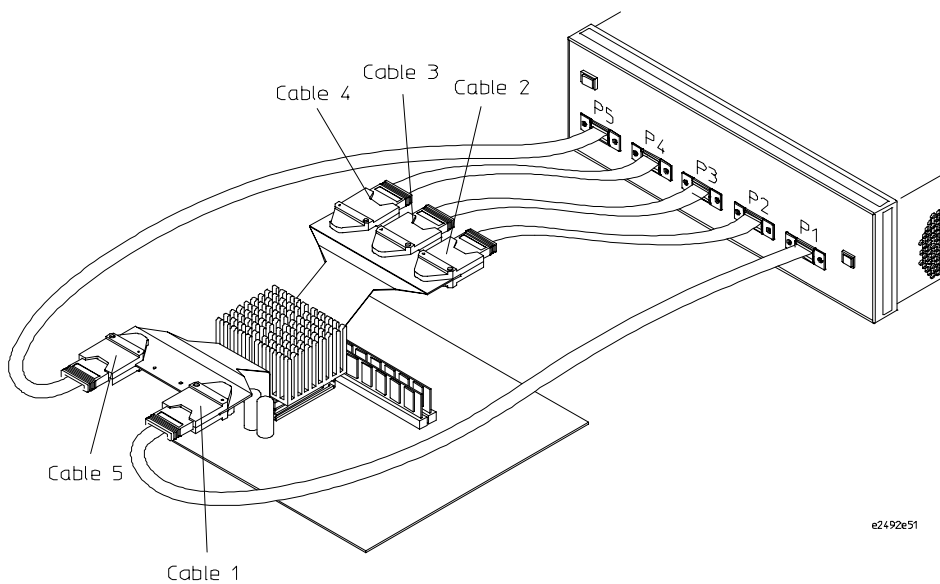

Operating characteristics

The following operating characteristics are not specifications, but are typical operating characteristics for the probe adapter.

Operating characteristics

Microprocessor Compatibility	Intel® Celeron™ processor in a 370-pin PPGA package
Power Requirements	The probe adapter draws a maximum 100 mA @ 5V, which is supplied by the logic analyzer. CAT I, Pollution degree 2.
Environment	The probe adapter is intended for indoor use only.
Environmental Temperature	Operating +5 to +40 degrees C Non operating -40 to +70 degrees C
Altitude	Operating 3,100 m (10,000 ft.) Non operating 4,600 m (15,000 ft.)
Humidity	Up to 80% non condensing. Avoid sudden, extreme temperature changes which could cause condensation within the instrument.
Bus Timing	The HP E2492D and the HP E2487A support systems meeting the typical bus timing specifications of Celeron processor systems with a bus speed of 66 MHz.

Cleaning

Signal Line Loading

The following schematics show the signal line loading.

GTL Signal Loading

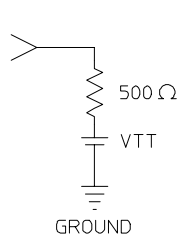

Non-GTL Signal Loading

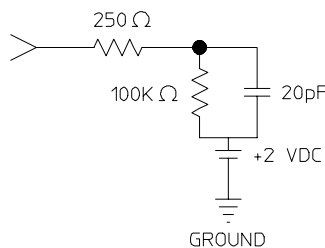

Clock Signal Loading

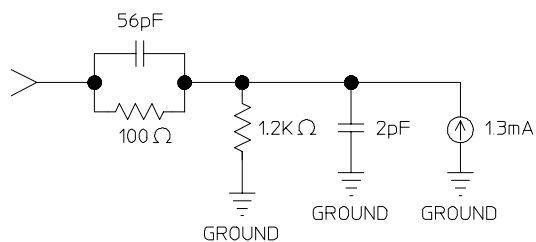

e2492b03

Cleaning

Remove any dust or debris from the probe adapter with precision dusting cleaner (otherwise known as inert dusting gas or compressed air).

Replaceable parts

The repair strategy for this probe adapter is product replacement. Contact your nearest Hewlett-Packard Sales Office.

Dimensions and minimum operating space

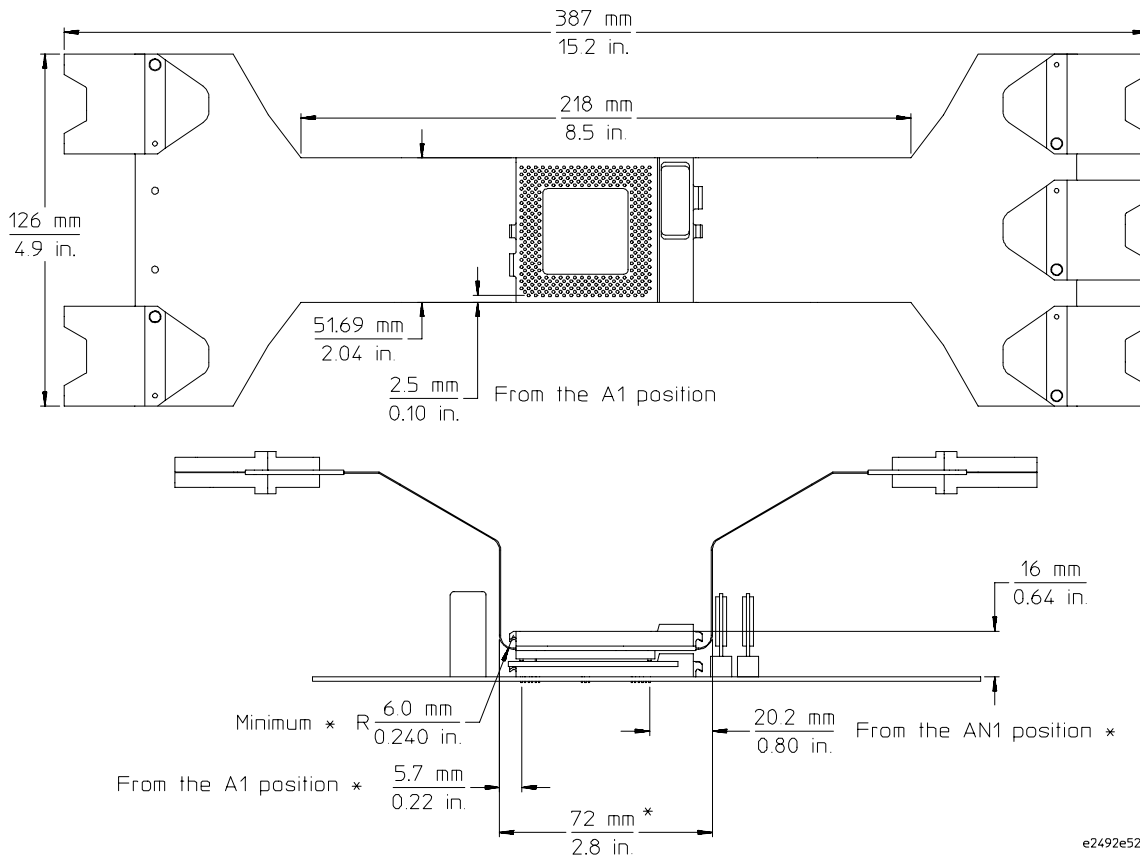

* = Recommended minimum operating space.

CAUTION

Bending the flexible cable beyond the minimum operating space will shorten the life of the probe adapter.

© Copyright Hewlett-Packard Company 1999
All Rights Reserved.

Reproduction, adaptation, or translation without prior written permission is prohibited, except as allowed under the copyright laws.

Restricted Rights Legend

Use, duplication, or disclosure by the U.S. Government is subject to restrictions set forth in subparagraph (C) (1) (ii) of the Rights in Technical Data and Computer Software Clause in DFARS 252.227-7013. Hewlett-Packard Company, 3000 Hanover Street, Palo Alto, CA 94304 U.S.A. Rights for non-DOD U.S. Government Departments and Agencies are set forth in FAR 52.227-19(c)(1,2).

Document Warranty

The information contained in this document is subject to change without notice.

Hewlett-Packard makes no warranty of any kind with regard to this material, including, but not limited to, the implied warranties of merchantability or fitness for a particular purpose.

Hewlett-Packard shall not be liable for errors contained herein or for damages in connection with the furnishing, performance, or use of this material.

Safety

This apparatus has been designed and tested in accordance with IEC Publication 348, Safety Requirements for Measuring Apparatus, and has been supplied in a safe condition. This is a Safety Class I instrument (provided with terminal for protective earthing). Before applying power, verify that the correct safety precautions are taken (see the following warnings). In addition, note the external markings on the instrument that are described under "Safety Symbols."

Warning

- Service instructions are for trained service personnel. To avoid dangerous electric shock, do not perform any service unless qualified to do so. Do not attempt internal service or adjustment unless another person, capable of rendering first aid and resuscitation, is present.
- Whenever it is likely that the ground protection is impaired, you must make the instrument inoperative and secure it against any unintended operation.
- Do not operate the instrument in the presence of flammable gasses or fumes. Operation of any electrical instrument in such an environment constitutes a definite safety hazard.
- Do not install substitute parts or perform any unauthorized modification to the instrument.

Safety Symbols



Instruction manual symbol: the product is marked with this symbol when it is necessary for you to refer to the instruction manual in order to protect against damage to the product.



Hazardous voltage symbol.



Earth terminal symbol: Used to indicate a circuit common connected to grounded chassis.

WARNING

The Warning sign denotes a hazard. It calls attention to a procedure, practice, or the like, which, if not correctly performed or adhered to, could result in personal injury. Do not proceed beyond a Warning sign until the indicated conditions are fully understood and met.

CAUTION

The Caution sign denotes a hazard. It calls attention to an operating procedure, practice, or the like, which, if not correctly performed or adhered to, could result in damage to or destruction of part or all of the product. Do not proceed beyond a Caution symbol until the indicated conditions are fully understood or met.

Product Warranty

This Hewlett-Packard system product is warranted against defects in material and workmanship for a period of one year from date of purchase. Some newly manufactured HP products may contain remanufactured parts which are equivalent to new in performance. Some newly manufactured products may contain remanufactured parts which are equivalent to new in performance. During the warranty period, Hewlett-Packard Company will, at its option, either repair or replace products that prove to be defective. Products must be returned to a service facility designated by HP.

For products returned to Hewlett-Packard for warranty service, the Buyer shall prepay shipping charges to Hewlett-Packard and Hewlett-Packard shall pay shipping charges to return the product to the Buyer. However, the Buyer shall pay all shipping charges, duties, and taxes for products returned to Hewlett-Packard from another country.

Hewlett-Packard warrants that its software and firmware designated by Hewlett-Packard for use with an instrument will execute its programming instructions when properly installed on that instrument. Hewlett-Packard does not warrant that the operation of the instrument software, or firmware will be uninterrupted or error free.

Limitation of Warranty

The foregoing warranty shall not apply to defects resulting

from improper or inadequate maintenance by the Buyer, Buyer-supplied software or interfacing, unauthorized modification or misuse, operation outside of the environmental specifications for the product, or improper site preparation or maintenance.

No other warranty is expressed or implied. Hewlett-Packard specifically disclaims the implied warranties of merchantability or fitness for a particular purpose.

Exclusive Remedies

The remedies provided herein are the buyer's sole and exclusive remedies. Hewlett-Packard shall not be liable for any direct, indirect, special, incidental, or consequential damages, whether based on contract, tort, or any other legal theory.

Assistance

Product maintenance agreements and other customer assistance agreements are available for Hewlett-Packard products.

For any assistance, contact your nearest Hewlett-Packard Sales Office.

Certification

Hewlett-Packard Company certifies that this product met its published specifications at the time of shipment from the factory. Hewlett-Packard further certifies that its calibration measurements are traceable to the United States National Institute of Standards and Technology, to the extent allowed by the Institute's calibration facility, and to the calibration

facilities of other International Standards Organization members.

About this edition

This is the first edition of the *HP E2492D Probe Adapter for the Intel®Celeron™ Processor Installation Guide*.

Publication number
E2492-92005, May 1999
Printed in USA.

Edition dates are as follows:
E2492-92005, May 1999
E2492-92004, February 1999

New editions are complete revisions of the manual. Many product updates do not require manual changes and manual corrections may be done without accompanying product changes. Therefore, do not expect a one-to-one correspondence between product updates and manual updates.

Intel is a U.S. registered trademark and Celeron is a U.S. trademark of Intel Corporation.



HP Part Number E2492-92004
Printed February 1999